

## 後拉式油壓夾頭

新產品  
**NEW**

後拉式油壓夾頭作徑向夾持同時強力後拉，工件不會上浮，適用於鑄件及鍛件的加工。

1. 後拉式夾持將工件緊貼在基準面上，使夾持穩固，適於重切削。
2. 圓柱滑動結構，可長期使用，並確保重覆夾持的優異精度。
3. 準確的自定中心及強力夾持工件不上浮特性，要求長度精準的加工最適宜。
4. 可採用到位偵測，配合自動化系統。



### 尺寸圖 > Dimensions

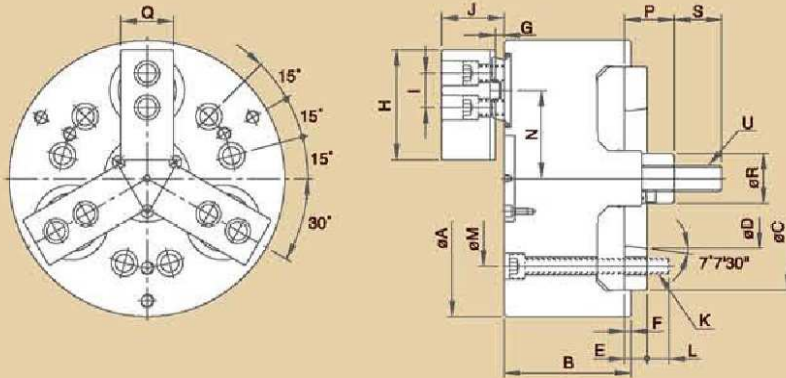

Pull back feature of radial gripping will lead to almost no work piece uplifting displacement; CHANOX Pull Back Power Chucks are ideal for machining casting and forging parts;

1. By appressing the gripped work piece to the surface, CHANOX Pull Back Power Chucks are suitable for heavy machining.
2. Chuck Actuators with cylindrical structure are durable and ensures high gripping repeatability.
3. Accurate self-centering and pull back features are adequate for precise length control machining requirements.
4. Optional components can be selected for detecting the right position on an automated loading machine.

### 規格表 > Specifications

單位/UNIT:mm

型式/規格 MODEL /SPEC.	A	B	C	D	E	F	G max.	G min.	H	J max.	J min.
PL-06	169	83	140	82.563	15	5	15	5	70	46	36
PL-08	210	97	170	106.375	17	5	16.5	6.5	84	57	47
PL-10	254	110	220	139.719	18	5	22	6	100	68	52
PL-12	304	125	220	139.719	18	5	21.5	5.5	120	72.5	56.5

型式/規格 MODEL /SPEC.	I	K	L	M	N max.	N min.	P max.	P min.	Q	R
PL-06	--	6-M10x1.5P	14	104.8	56.65	54	33	23	35	32
PL-08	26	6-M12x1.75P	17	133.4	69.65	67	38	28	40	38
PL-10	32	6-M16x2P	24	171.4	87.8	82	48	32	50	50
PL-12	36	6-M16x2P	20	171.4	102.8	97	47	31	60	52

型式/規格 MODEL /SPEC.	S	U	柱塞行程 Plunger Stroke (mm)	爪行程直徑 Jaw Stroke (Diameter) mm	最高迴轉速 Max.Speed r.p.m.(min <sup>-1</sup> )	最大拉力 Max. Pull Force kgf (KN)
PL-06	36	M16x2P	10	5.3	3500	1420 (14)
PL-08	36	M20x2.5P	10	5.3	3000	2240 (22)
PL-10	46	M24x3P	16	11.6	2500	3160 (31)
PL-12	50	M27x3P	16	11.6	2000	4480 (44)

型式/規格 MODEL /SPEC.	最大靜夾持力 Max. Gripping Force kgf (KN)		最大設定油壓壓力 Max. Hydr. Pressure kgf/cm <sup>2</sup> (Mpa)		淨重 Weight (kg)	搭配油壓缸型號 Matching Cylinder	夾持範圍 Gripping Range
PL-06	2950	(29)	22	(2.2)	15.4	L1020	ø35~ø160
PL-08	4890	(48)	22	(2.2)	27.8	L1225	ø40~ø210
PL-10	4990	(49)	30	(2.9)	45.9	L1225	ø50~ø254
PL-12	7240	(71)	30	(2.9)	75.7	L1530	ø50~ø304