

齒式二爪鋼殼夾頭

新產品
NEW

1. 可替代修整油壓生爪成型盤。
2. 爪仔可前後任意調整，加大夾持工件範圍。
3. 生爪及硬爪與CNC車床油壓爪共用。
4. 鋼殼結構於高速迴轉時安全性高，耐磨性強，使用壽命長。
5. 轉動板手扭力較小操作順暢。

尺寸圖 > Dimensions

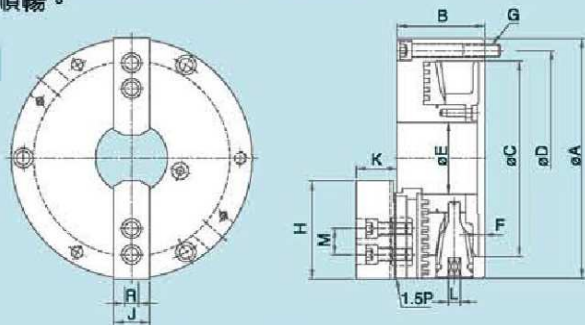

NT 3-JAW STEEL BODY CHUCKS

齒式三爪鋼殼夾頭

尺寸圖 > Dimensions

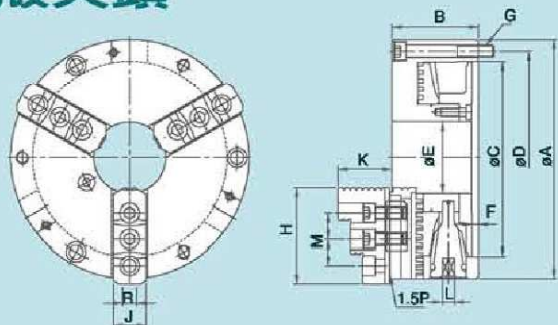

1. Can be used as a "Forming plate" for machining soft jaws.
2. Hard jaws and soft jaws can be adjusted just like on a power Chuck to increase the gripping range.
3. Hard jaws as well as Soft jaws are interchangeable with those of power chucks.
4. Chuck Body is made of steel to enhance safety operations for high speed machining.
5. The Chuck Handle can be operated easily and smoothly.

特點配合圖示說明 > Illustrate



可替代修整油壓生爪成型盤

The chuck can be used as a "Forming plate" for machining soft jaws.



爪仔可前後任意調整加大夾持工件範圍

Top jaws can be adjusted back and forth easily, thus increasing gripping range.



硬爪與油壓夾盤硬爪共用

Hard jaws are interchangeable with those of power chucks.



生爪與油壓夾盤生爪共用

Soft jaws are interchangeable with those of power chucks.

特別附件



連結盤

Optional accessory: Mounting plate.

規格表 > Specifications

單位/UNIT:mm

| 型式/規格 MODEL /SPEC. | A | B | C | D | E | F | G | H | J | K | L | M | R | 最高轉速 Max. Speed r.p.m.(min ⁻¹) | 把握範圍 Max.Gripping Diameter | | 淨重 Weight (kg) |
|--------------------------|-----|----|-----|-----|----|-----|-------------|----|----|----|----|----|----|---|-------------------------------|------------------------------|----------------------|
| | | | | | | | | | | | | | | | 外徑把握 O.D.Clamping (mm) | 內徑把握 I.D.Clamping (mm) | |
| TNT-07 | 193 | 78 | 155 | 172 | 58 | 5 | 3-M10x1.5P | 73 | 31 | 38 | 11 | 20 | 12 | 3200 | ø8~ø235 | ø66~ø235 | 14.4 |
| TNT-09 | 233 | 85 | 190 | 210 | 70 | 5.5 | 3-M12x1.75P | 95 | 35 | 40 | 12 | 25 | 14 | 2800 | ø11~ø280 | ø85~ø280 | 22.3 |

規格表 > Specifications

| | | | | | | | | | | | | | | | | | |
|-------|-----|-----|-----|-----|-----|-----|-------------|-------|----|----|----|----|----|------|----------|-----------|------|
| NT-07 | 193 | 78 | 155 | 172 | 58 | 5 | 3-M10x1.5P | 78 | 28 | 46 | 11 | 20 | 12 | 3200 | ø8~ø235 | ø66~ø235 | 13.1 |
| NT-09 | 233 | 85 | 190 | 210 | 70 | 5.5 | 3-M12x1.75P | 92 | 32 | 52 | 12 | 25 | 14 | 2800 | ø11~ø280 | ø85~ø280 | 21.2 |
| NT-10 | 275 | 91 | 230 | 250 | 89 | 5.5 | 3-M12x1.75P | 101.5 | 37 | 56 | 12 | 30 | 16 | 2400 | ø12~ø330 | ø92~ø330 | 30.5 |
| NT-12 | 310 | 104 | 260 | 285 | 105 | 7 | 3-M12x1.75P | 116 | 47 | 67 | 14 | 30 | 21 | 2100 | ø15~ø370 | ø104~ø370 | 46.1 |