

FKT 4-JAW POWERFUL TYPE ADJUSTMENT STEEL BODY CHUCKS

可調式強力型四爪鋼殼夾頭

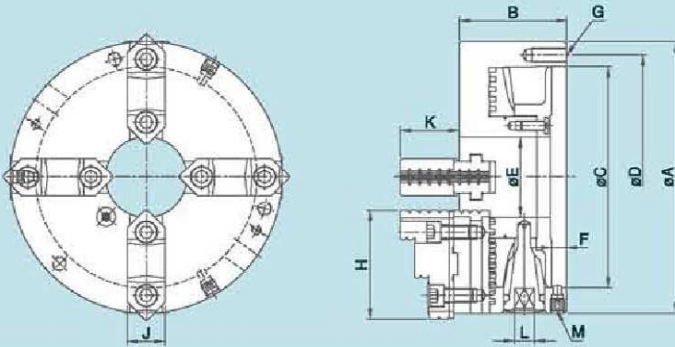

尺寸圖 > Dimensions



規格表 > Specifications

單位/UNIT:mm

型式/規格 MODEL /SPEC.	A	B	C	D	E	F	G	H	J	K	L	M	最高迴轉速 Max.Speed r.p.m.(min ⁻¹)	把握範圍 Max. Gripping Diameter		淨重 Weight (kg)
														外徑把握 O.D.Clamping	內徑把握 I.D.Clamping	
FKT-07	193	85	155	172	58	12	3-M10x1.5P	82	28	43	11	3-M12x1.75P	3500	ø8~ø180	ø62~ø170	14.1
FKT-09	233	92	190	210	70	12.5	3-M12x1.75P	93	32	51	12	3-M12x1.75P	2900	ø11~ø220	ø70~ø210	22
FKT-10	275	98	230	250	89	12.5	3-M12x1.75P	102	35	54	12	3-M12x1.75P	2500	ø12~ø260	ø80~ø250	33.5
FKT-12	310	111	260	285	105	14	3-M12x1.75P	118	40	58	14	3-M12x1.75P	2200	ø15~ø300	ø90~ø290	46.1

KT 3-JAW POWERFUL TYPE ADJUSTMENT STEEL BODY CHUCKS

可調式強力型三爪鋼殼夾頭



尺寸圖 > Dimensions

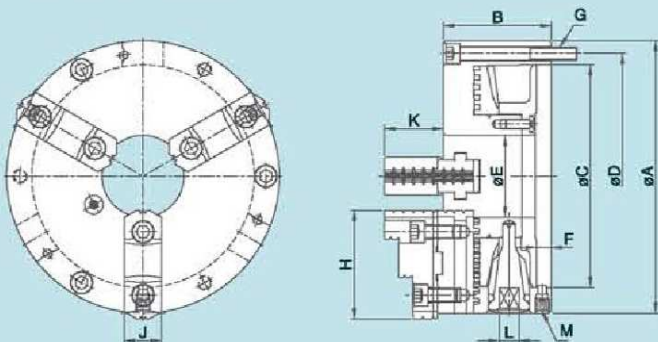

規格表 > Specifications

單位/UNIT:mm

型式/規格 MODEL /SPEC.	A	B	C	D	E	F	G	H	J	K	L	M	最高迴轉速 Max.Speed r.p.m.(min ⁻¹)	把握範圍 Max. Gripping Diameter		淨重 Weight (kg)
														外徑把握 O.D.Clamping	內徑把握 I.D.Clamping	
KT-06	167	75.5	130	147	45	12	3-M10x1.5P	68	26	39	10	3-M12x1.75P	4000	ø8~ø160	ø55~ø150	9.7
KT-07	193	85	155	172	58	12	3-M10x1.5P	82	28	43	11	3-M12x1.75P	3500	ø8~ø180	ø62~ø170	13.6
KT-09	233	92	190	210	70	12.5	3-M12x1.75P	93	32	51	12	3-M12x1.75P	2900	ø11~ø220	ø70~ø210	21.5
KT-10	275	98	230	250	89	12.5	3-M12x1.75P	102	35	54	12	3-M12x1.75P	2500	ø12~ø260	ø80~ø250	30.4
KT-12	310	111	260	285	105	14	3-M12x1.75P	118	40	58	14	3-M12x1.75P	2200	ø15~ø300	ø90~ø290	45.4